

Adjusting the Rear Suspension

CBR1000RR/RA

Spring Preload

You can adjust the spring preload by the adjuster to suit the load or the road surface. Use a suitable pin spanner to turn the adjuster. Positions 1 to 3 are for a decrease spring preload (soft), or turn the position 5 to 10 increase spring preload (hard). The standard position is 4.

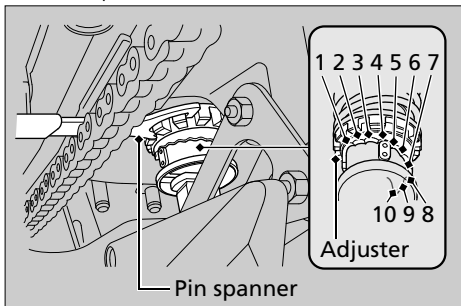

Rebound Damping

You can adjust the rebound damping by the TEN adjuster to suit the load or the road surface.

Turn clockwise to increase rebound damping (hard), or turn counterclockwise to decrease rebound damping (soft). The standard position is 2 1/2 turns from the full hard position.

