

## Adjusting the Rear Suspension

Adjusting the suspension requires a pin spanner. We recommend that you have your motorcycle serviced by your dealer.

### Spring Preload

You can adjust the spring preload by the adjuster to suit the load or the road surface. Turn the adjuster using a suitable pin spanner and extension bar.

The preload adjuster has 9 positions. The standard position is 4 when the index mark on the adjuster is aligned with the left end of the rear shock absorber lower mounting bolt. Turn the adjuster in the direction A to decrease spring preload (soft) (position 1 to 3), or turn the adjuster in the direction B to increase spring preload (hard) (position 5 to 9).

#### NOTICE

Attempting to adjust directly from 1 to 9 or 9 to 1 may damage the shock absorber.

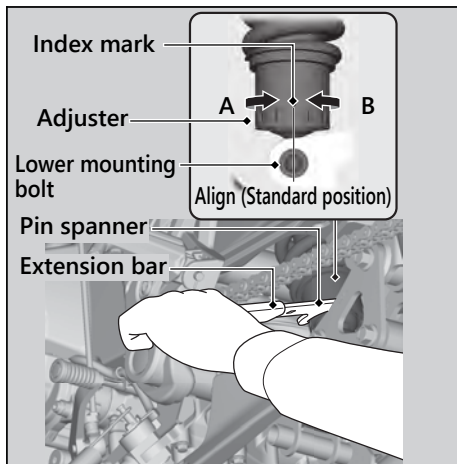

#### NOTICE

Do not turn the adjuster beyond its limits.