

## Rebound Damping

You can adjust the rebound damping by the TEN adjuster to suit the load or the road surface.

The TEN adjuster has 5 1/2 turns from the full hard position.

Turn clockwise to increase rebound damping (hard), or turn counterclockwise to decrease rebound damping (soft). The standard position is 5 turns from the full hard position.

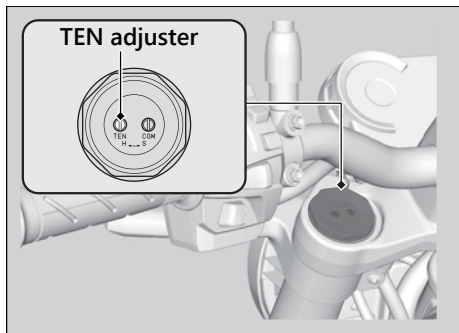

### NOTICE

Do not turn the adjuster beyond its limits.